



INSTRUCTION MANUAL

CZECH UP YOUR BEER
COOLING AND DISPENSING SYSTEMS

LINDR FLOW-THROUGH CONTACT COOLER

ENGLISH

Number 012-2020 REV00 Valid 2020-06-01



LINDR.CZ s.p.o.
CHLADICÍ A VÝČEPNÍ TECHNIKA



CZECH UP YOUR BEER

COOLING AND DISPENSING SYSTEMS

IMPORTANT

This manual contains instructions for installation, use and operation of the appliance. This manual is an integral part of the device. It must be stored in the vicinity of the device for the entirety of its service life and must be made available to the user any time the device is installed, moved, used or maintained. Read this manual carefully before installing and using the device. It contains important information necessary to ensure that all operations are done properly and safely.

This manual is a translation of the original Czech manual.

LINDR.CZ s.r.o.

Sadová 132
503 15 Nechanice, Czech Republic

mobile: + 420 775 715 494
tel.:+420 495 447 239

e-mail: info@lindr.cz
web: www.lindr.cz, www.lindr.eu

SYMBOLS AND MARKINGS USED IN THE MANUAL:



WARNING:

Not following instructions may cause injury or damage the device.



DANGER:

Risk of injury by electrical current.



NOTE:

This symbol indicates information and recommendations for the user.



WARNING:

The cooling system contains flammable coolant R290 (propane)!





Contents:

1.	Introduction	4
2.	Description of the cooler	4
3.	Machine plate	4
4.	General instructions, measures and safety instructions	4
5.	Installation and placement	5
6.	Electrical connection	6
7.	Testing	6
8.	Warranty	6
9.	Package contents	6
10.	Tap installation	7
11.	Keg coupler assembly	7
12.	Beverage supply connection and pressurisation	9
13.	Connection and regulation of KONTAKT 155/R	12
14.	How to work with speed fittings	12
15.	Temperature and adjustment	13
16.	Keg tapping and untapping	14
17.	Putting into operation	16
18.	Table of malfunctions	17
19.	Spare parts	18
20.	Sanitation by water	18
21.	Maintenance	19
22.	Inspection before every use	19
23.	Periodic checks	19
24.	Environmental protection	19

1. INTRODUCTION:

Thank you for purchasing this LINDR product.

2. DESCRIPTION OF THE COOLER

This beverage dispensing system with built-in compressor is designed for cooling, dispensing and serving well-cooled beer and beverages.

The modern Lindr compressor cooling unit uses input energy and transforms it directly into cooling, ensuring proper beer cooling at minimum energy drain.

This manual is intended for models:

PYGMY 30/K profi

and GREEN LINE models:

PYGMY 20

PYGMY 20/K

PYGMY 25

PYGMY 25/K

KONTAKT 40

KONTAKT 40/K

KONTAKT 40/K profi

KONTAKT 70

KONTAKT 70/K

KONTAKT 155

KONTAKT 155/K

KONTAKT 155/R

3. MACHINE PLATE



4. GENERAL INSTRUCTIONS, MEASURES AND SAFETY INSTRUCTIONS

When using the device, follow basic safety instructions stated by the manufacturer. The cooling device is designed for flow-through cooling of beverages. Any other use is consid-

ered impermissible and therefore dangerous. The supplier is not liable for damage caused by incorrect use.

DO NOT USE THE DEVICE FOR PURPOSES OTHER THAN THOSE STATED BY THE MANUFACTURER!

General safety principles. Observe the following safety instructions.

The supplier is not liable for damage caused by activities carried out on this device without observing the following instructions!

⚠ WARNING: Children aged 15 or more and persons with reduced physical, sensory or mental capabilities or insufficient experience and knowledge may only use the device when supervised or instructed in safe use of the appliance and familiarised with potential dangers.

⚠ WARNING: Children must not be allowed to play with the appliance. Store all packaging material out of reach of children (*comes with a plastic bag – suffocation hazard*).

⚠ WARNING: Cleaning and maintenance of the appliance on the part of the user must not be done by unsupervised children.

⚠ WARNING: Before connecting to main electrical supply, check that the voltage and frequency in the mains corresponds to the data stated on the device.

⚠ WARNING: Always make sure that the socket you intend to plug the cooler into meets the specifications on the machine plate (voltage, frequency, input power).

⚠ WARNING: Before performing operations on the device such as cleaning or maintenance, ALWAYS disconnect the device from power supply: set the thermostat to "O" position and unplug the appliance from the socket.

⚠ WARNING: Never place tools or other object into the fan.

⚠ WARNING: Never touch electrical components with wet or damp hands.

⚠ WARNING: To ensure the cooling unit works properly and at full capacity, make sure air supply to the unit is not obstructed.

⚠ WARNING: Water temperature during sanitation must not be higher than 25 °C!

⚠ WARNING: Always make sure the power socket you intend to plug the cooler into is accessible, so that the appliance can be immediately unplugged in case of emergency.

⚠ WARNING: When unplugging the device from the socket, grab the plug and pull it out. Do not under any circumstances pull at the cable; risk of damage.

⚠ WARNING: To turn the device off completely, unplug the appliance from the power socket.

⚠ WARNING: In the event the electrical wiring of the product becomes damaged, summon a trained service technician. Do not under any circumstances repair the device yourself.

⚠ WARNING: The cooling system contains flammable coolant R290 (propane)!



⚠ WARNING: Emergency maintenance and repair of the cooling system must be done by trained, authorised technicians familiar with cooling and electrical systems. The technicians should have special training and qualification for handling flammable substances in order to perform service on coolers containing R290. Follow basic regulations and safety measures regarding service and repair!

⚠ WARNING: Do not use open flame or potential sources of sparks in the vicinity of a cooler using **R290** coolant!

⚠ WARNING: After unpacking, place the cooler so that heat created by the cooling unit can be vented sufficiently.

⚠ WARNING: Do not place objects that could prevent air circulation on top of the cooler.

5. INSTALLATION AND PLACEMENT

Place the cooler onto a stable, level surface (maximum permitted inclination: 2 degrees). The appliance requires unobstructed air circulation.

- Ensure sufficient free space for air circulation and heat dissipation.
- Ensure sufficient supply of fresh air.
- The device must not be placed in an enclosed space.
- The device must not be placed in the vicinity of heat sources or exposed to direct sunlight.

Minimum distance of vents from an obstacle that would limit air circulation must be 30 cm. Minimum distance for sections with no air vents is 7 cm. Ideally, use the device in a cool and well-ventilated room. The device is designed for use at ambient temperature of at least 16 °C and at most 32°C.

⚠ WARNING: The device MUST NOT be used or stored at ambient temperature lower than 0 °C. The device is designed for use in a normal environment, always under a roof, protected from rain or sunlight. Climate class N.

⚠ DANGER: Protect the cooler and electrical connection from rain and spraying water!

⚠ WARNING: Do not under any circumstances lay the cooler on its side, not even during transport.

i NOTE: In order for the device to work correctly and at maximum output, it is important to not cover up any of the device's vents and ensure sufficient air circulation.

6. ELECTRICAL CONNECTION

Connect the device to a power socket in accordance with specifications on the machine plate of the device. Electrical wiring is subject to local regulations. If the power leads (cables) are damaged, they must be replaced by the manufacturer, their service technician or a similarly qualified person to prevent risk of hazardous situations.

⚠ DANGER: Do not use or turn on the device if the power lead (cable) is damaged!

7. TESTING

The product is delivered ready for immediate use.

8. WARRANTY

The device comes with a warranty in accordance with general legal regulations of the Czech Republic or in accordance with the trade agreement. During the validity period of the warranty, we will remove any defects on the product free of charge, provided these defects were not caused by excess wear, improper handling, incorrect storage or by using the

product in a way that is counter to the instruction manual or the product's design as defined by the manufacturer. Materials replaced during the validity period of the warranty are our property. The legitimacy of the warranty claim is always decided by an authorised service centre. Warranty provided by a retailer outside of the territory of the Czech Republic is governed by the agreement between the retailer and the buyer in their mutual relationship; this agreement is not directly linked to the manufacturer. The agreement does not give the buyer the right to submit warranty claims to the manufacturer. Transport expenses or other costs are not covered by the warranty.

ATTENTION:

Electrical devices and appliances must be checked/inspected at a time stipulated by valid legislation of the country the device is operated in. Inspection of wiring may only be done by a person with valid authorisation for this activity. Service work, provision of spare parts and inspection is done by the manufacturer or an authorised service centre.

9. PACKAGE CONTENTS

1. Tap (Packaging of the two-tap device contains 2 taps.)
2. Drip tray
3. Tap wrench

1.



2.

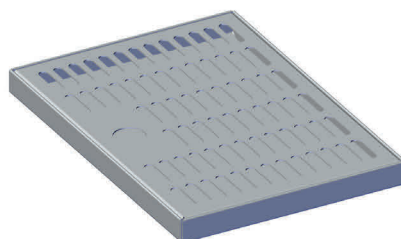

3.



10. TAP INSTALLATION

1.

Turn the compensator lever (1.), so that it points down (see figure). The compensator lever on the tap is used to adjust the flow rate.

figure 7A

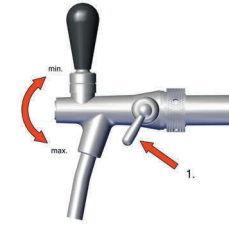

2.

Fit the tap perpendicularly onto the spline.

figure 7B

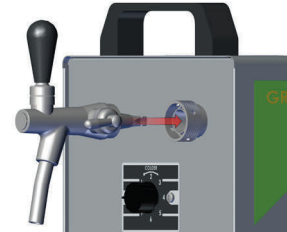

3.

Secure with a flare nut and turn left. (loosen to the right).

figure 7C



4.

Tighten with the enclosed wrench.

figure 7D



11. KEG COUPLER ASSEMBLY

11.1 Outlet for Keg Pressurisation

Variant of connection with the use of a bushing; the hose is fitted onto the bushing and affixed with a clip.

figure 7E

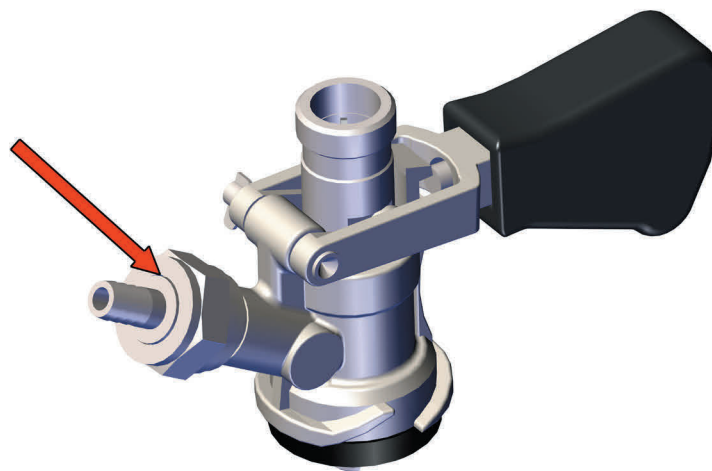

figure 8 A

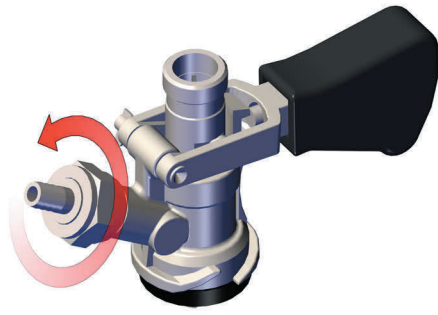

figure 8 B

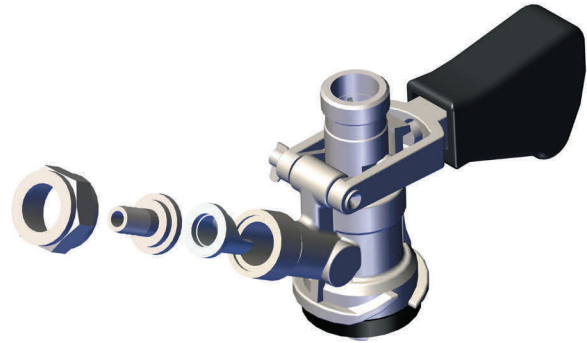

figure 8 C

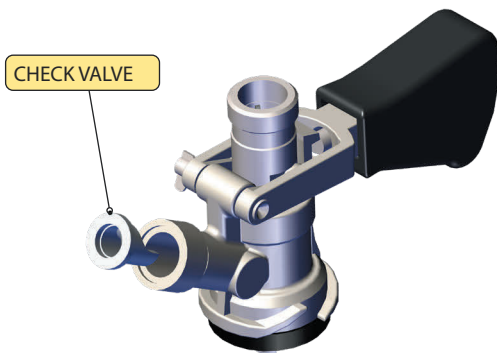
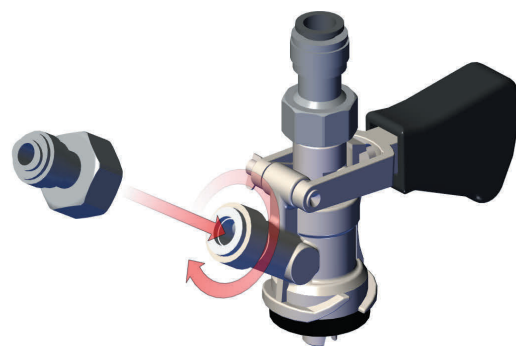

figure 8 D



⚠ WARNING: Before you screw the speed fitting onto the 5/8" thread, make sure the keg coupler (air inlet for delivery medium) has a lip valve (check valve) fitted on it.

11.2 Outlet for Beverage

Screw an F 5/8" x 3/8" (9,5 mm) speed fitting onto the keg coupler.

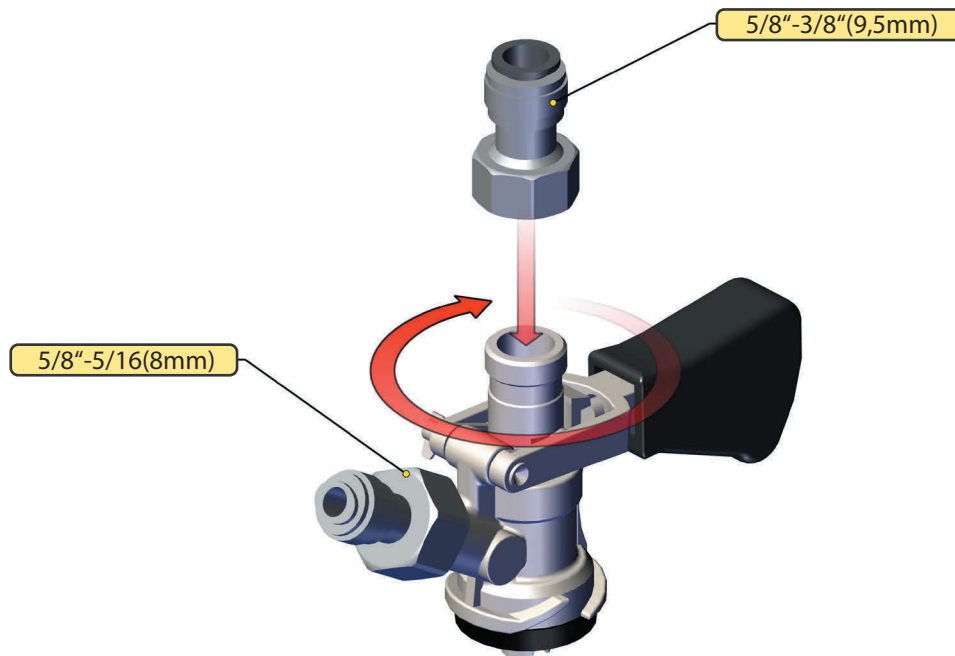

12. BEVERAGE SUPPLY CONNECTION AND PRESSURISATION

12.1 Connection and Pressurisation by Built-In Compressor (One-Tap Device)

- | | |
|---|-------------------------------|
| 1. Beverage inlet | 5. F 5/8x9.5 mm speed fitting |
| 2. Air outlet | 6. F 5/8x8 mm speed fitting |
| 3. Compressor switch | 7. Beverage |
| 4. Keg coupler (A-system, S-system, M-system) | |

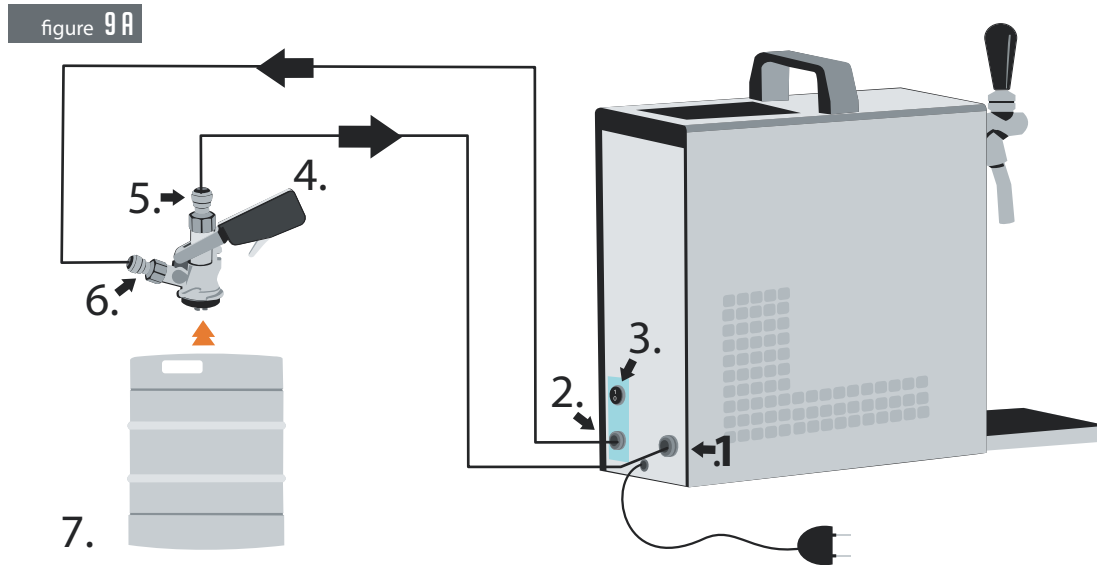

12.2 Connection and Pressurisation by CO₂ Bottle (One-Tap Device)

- | | |
|---|---|
| 1. Beverage inlet | 5. Pressure regulator for CO ₂ mini bottle |
| 2. Keg coupler (A-system, S-system, M-system) | 6. F 7/16 x 8 mm speed fitting |
| 3. F 5/8x9.5 mm speed fitting | 7. Beverage |
| 4. F 5/8x8 mm speed fitting | |

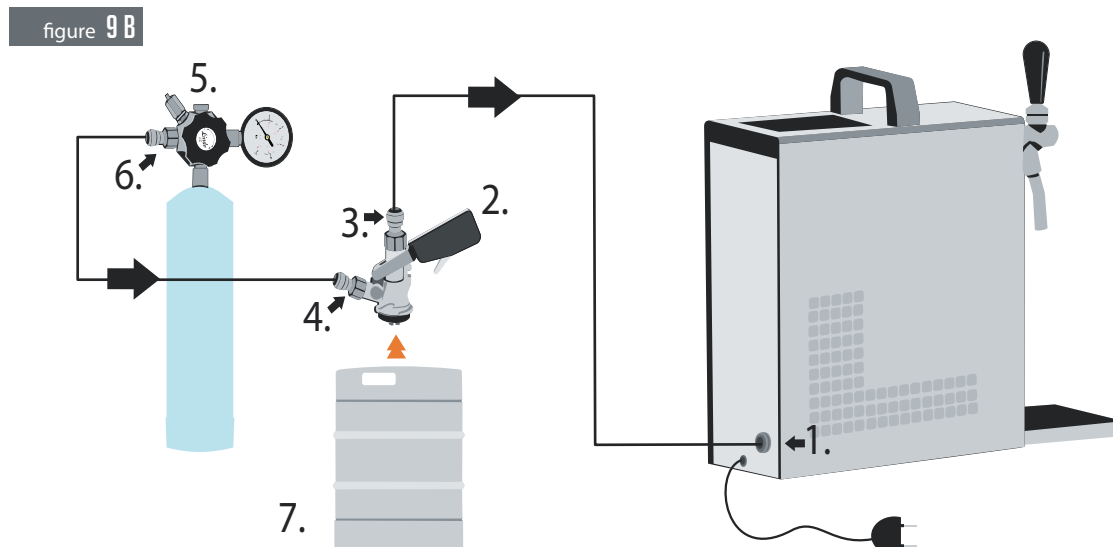

12.3 Connection and Pressurisation by Built-In Compressor (Two-Tap Device)

- | | |
|---|---------------------------------|
| 1. Beverage inlet | 5. F 5/8 x 8 mm speed fitting |
| 2. Air outlet | 6. Y 8 x 8 x 8 mm speed fitting |
| 3. Keg coupler (A-system, S-system, M-system) | 7. Beverage |
| 4. F 5/8 x 9.5 mm speed fitting | 8. Compressor switch |

figure 10 A

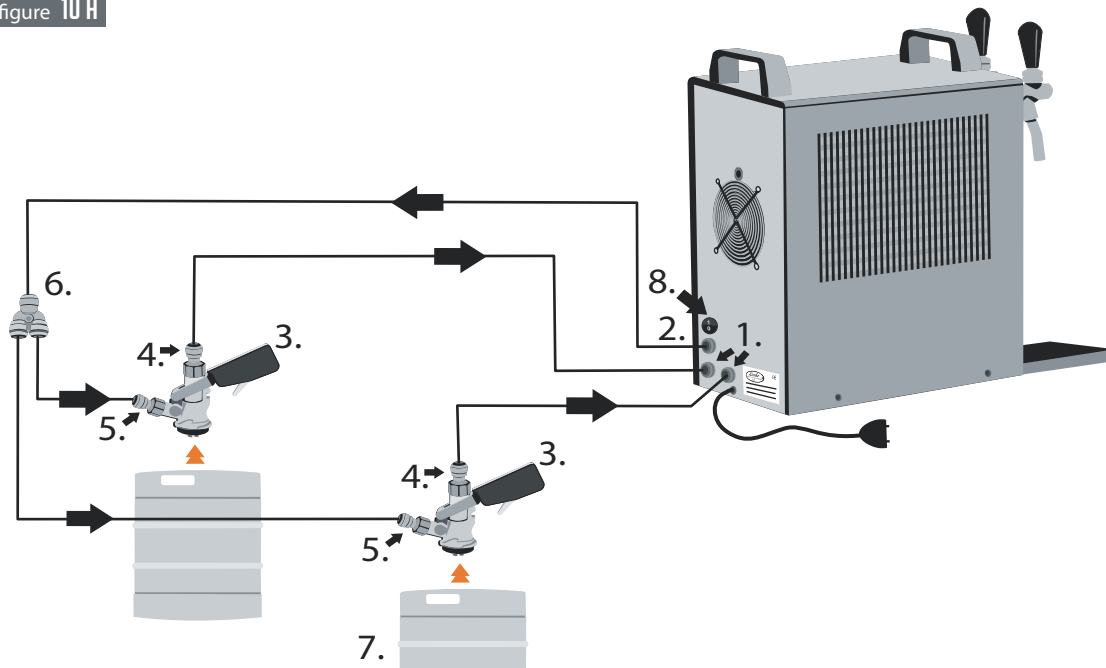

Built-In Air Compressor

Only for PYGMY 30/K profi models with built-in air compressor and GREEN LINE models PYGMY 20/ K, PYGMY 25/ K, KONTAKT 40/K, KONTAKT 70/ K, KONTAKT 155/ K.

The air mini-compressor is built into the cooling device itself. Automatic pressure regulation is set to 2.8-3.2 bar. K profi models allow smooth pressure regulation in 1.0-3.4 bar range. The set pressure will be displayed on the pressure gauge in bars. The compressor can be turned off separately with a switch. The air outlet from the cooler terminates in a 5/16" (8 mm) speed fitting marked AIR. The air compressor is zero-maintenance, fitted with a molecule filter for the drawn-in air.

12.4 Connection and Pressurisation by Classic CO₂ Bottle (Two-Tap Device)

- | | |
|---|--|
| 1. Beverage inlet | 5. Y 8 x 8 x 8 mm speed fitting |
| 2. Keg coupler (A-system, S-system, M-system) | 6. CO ₂ pressure reducing valve |
| 3. F 5/8 x 9.5 mm speed fitting | 7. F 7/16 x 8 mm speed fitting |
| 4. F 5/8 x 8 mm speed fitting | 8. Beverage |

figure 11 A

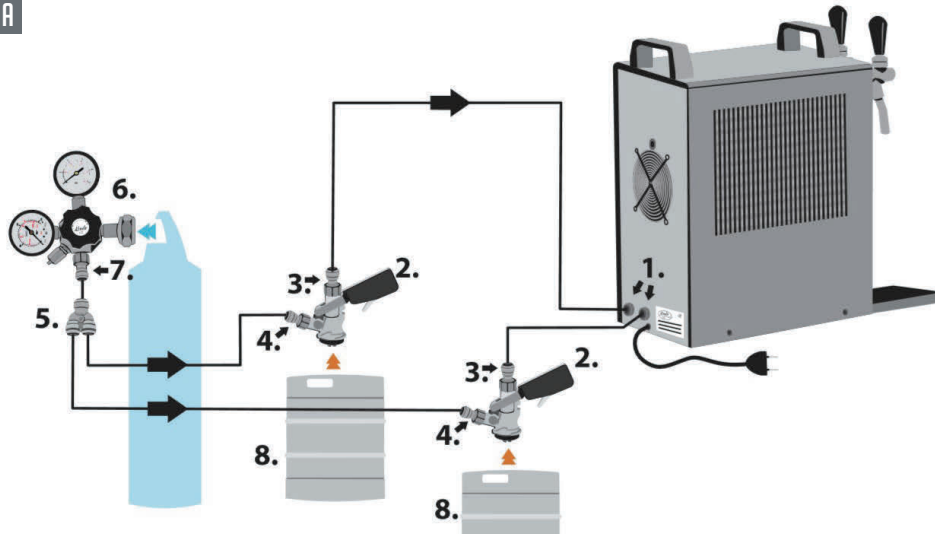

Other Pressurisation Options

By PUMA 1HP and 1/2HP compressor, LEONARDO 1HP compressor, AIRCRAFT 1HP compressor, classic Biogon, N₂ bottles.

12.5 Connecting KONTAKT 155/R to Pressurisation with a Classic CO₂ Bottle (Two-Tap Device)

- | | |
|---|--|
| 1. Beverage inlet | 5. F 5/8 x 9.5 mm speed fitting |
| 2. CO ₂ outlet | 6. F 5/8 x 8 mm speed fitting |
| 3. Pressure control | 7. High-pressure hose with W 21.8 flare nut; pressurised bottles with a G3/4 thread require an adapter for K 115/R |
| 4. Keg coupler (A-system, S-system, M-system) | 8. Beverage |

figure 11 B

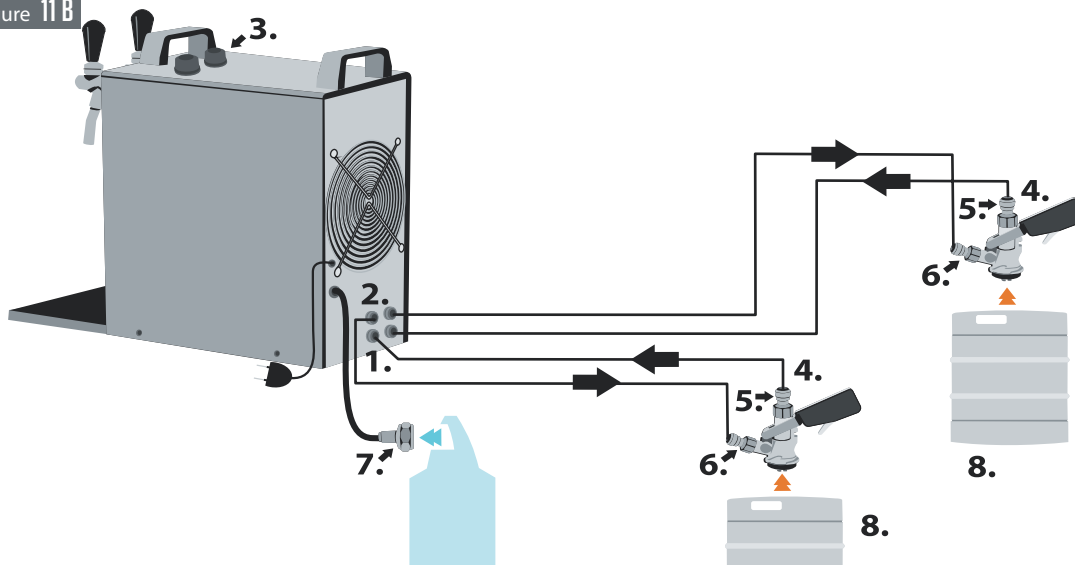

13. CONNECTION AND REGULATION OF KONTAKT 155/R WITH CO₂ PRESSURE BOTTLE

1. Screw speed fittings onto the keg coupler.
2. Plug 3/8" and 5/16" hoses into the speed fittings on the keg coupler.
3. Connect the 3/8" and 5/16" hose with the speed fittings located on the cooler in accordance with the description found on the label above the speed fittings.
4. Screw the high pressure hose onto the CO₂ bottle using a flare nut.
5. Fit the keg couplers onto the beverage keg, but leave the keg coupler in closed position (top position).
6. Open the valve on the CO₂ bottle and use the regulating screws on the top of the cooler to set the desired pressure for both the separate beverage lines. (The set pressure is displayed on the pressure gauges located on the front of the cooler).
7. Tap the keg using the keg coupler.

⚠ WARNING: Check that all joints are sufficiently leak-tight after connection.

If everything is in order, check the thermostat settings (in off position). Connect the cooler to the power mains. Then use the keg coupler to tap the keg, set the desired pressure (1.0-3.4 bar) and use the tap lever to pour out some of the beverage. If the cooler contains remnants of sanitation solution or water, keep the tap lever in open position until only beverage pours out of the tap. Set the desired beverage temperature on the thermostat.

12

14. HOW TO WORK WITH SPEED FITTINGS

14.1 Speed Fitting Installation

figure 12 B

Grasp the speed fitting and insert the hose all the way inside the speed fitting body (ca. 20 mm). The end of the hose must be straight so that it plugs fully into the coupling. If the hose will not go in, moisten the end of the hose.

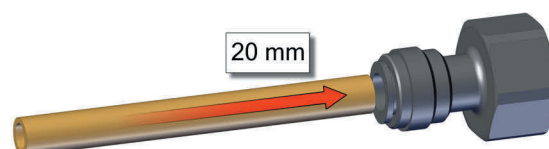

14.2 Speed Fitting Removal

figure 13 C

Hold the grey ring tight against the body of the speed fitting and pull out the hose.

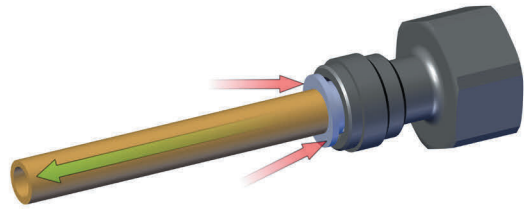

! WARNING: If you do not hold the grey ring but pull at the hose, the speed fitting will cut even deeper into the hose.

! WARNING: Hoses must not be pressurised during removal.

15. TEMPERATURE AND ADJUSTMENT

The temperature of the cooled beverage is controlled by a mechanical thermostat in temperature range of 2 °C to 8 °C.

The thermostat has a numerical scale of 1-7.

figure 13 B



0 = OFF

figure 13 C



1 = MAX. BEVERAGE
TEMPERATURE (8°C)

figure 13 D



7 = MIN. BEVERAGE
TEMPERATURE (2°C)

! WARNING: If you are using the cooler to cool non-alcoholic beverages, set the thermostat knob to 5 at the most, otherwise, there is a risk of the beverage freezing in the cooler's tubing and damaging the device.

16. KEG TAPPING AND UNTAPPING

16.1 Keg Tapping

Procedure for tapping a keg using an S-system keg coupler:

⚠ WARNING: Make sure the adapter is clean before tapping the keg!

S-system keg coupler

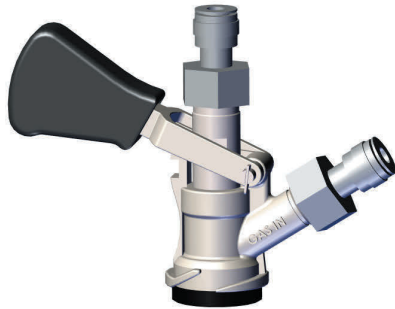

figure 14 A

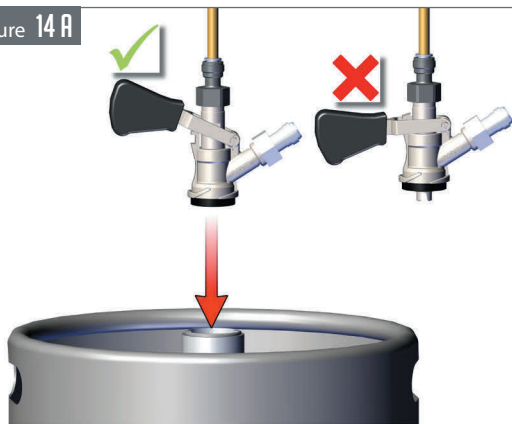

figure 14 B

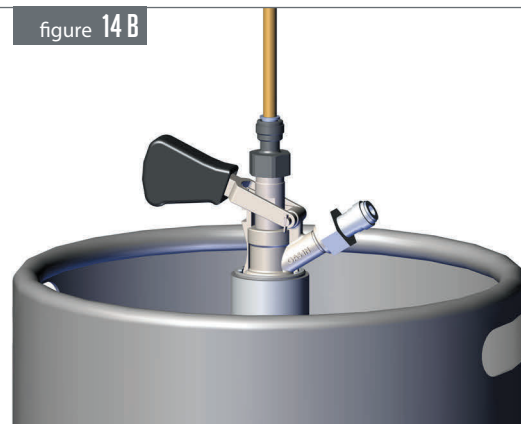

figure 14 C



figure 14 D

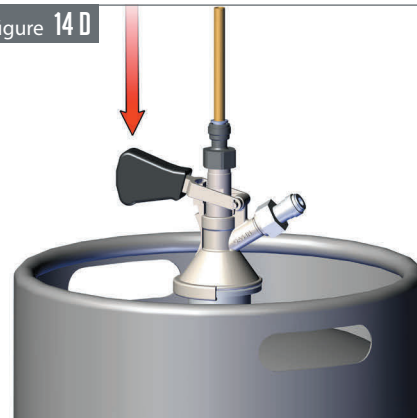
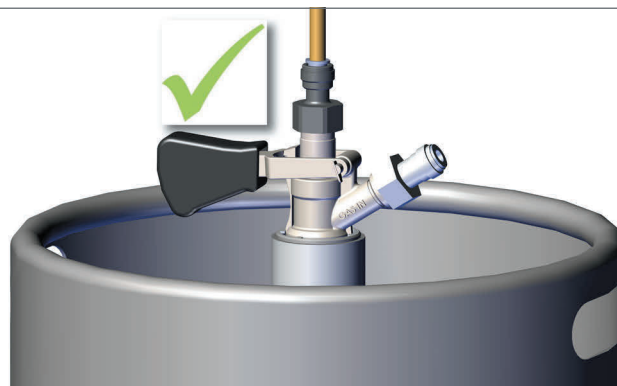

figure 14 E



16.2 Keg Untapping

Procedure for untapping a keg using an S-system keg coupler:

figure 15 A

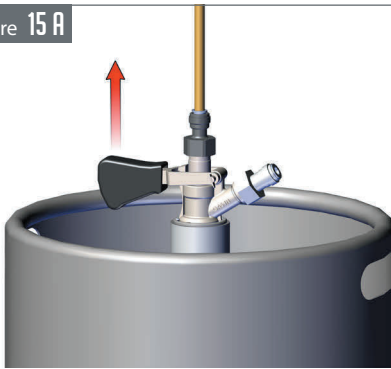
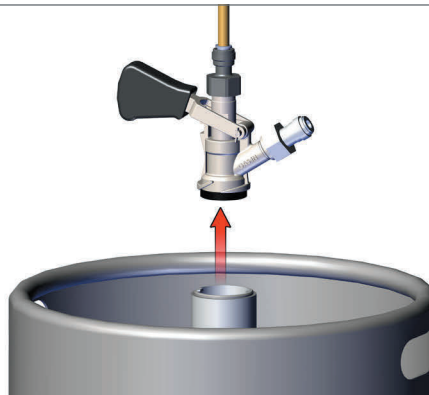

figure 15 B



figure 15 C



16.3 Keg Tapping

Procedure for tapping a keg using an A-system keg coupler:

⚠ WARNING: Make sure the adapter is clean before tapping the keg!

A-system keg coupler

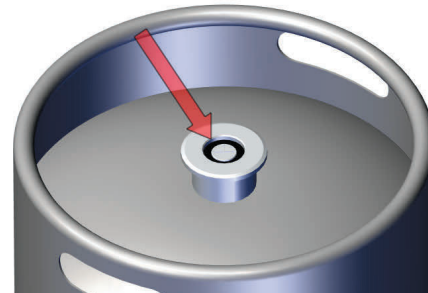
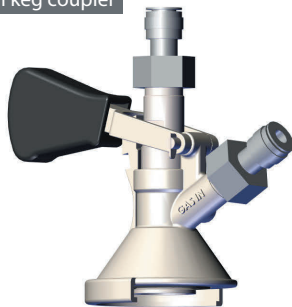

figure 15 D

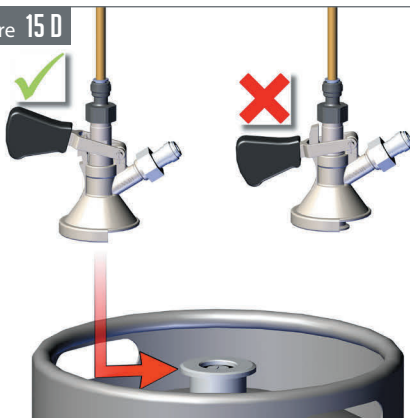

figure 15 E

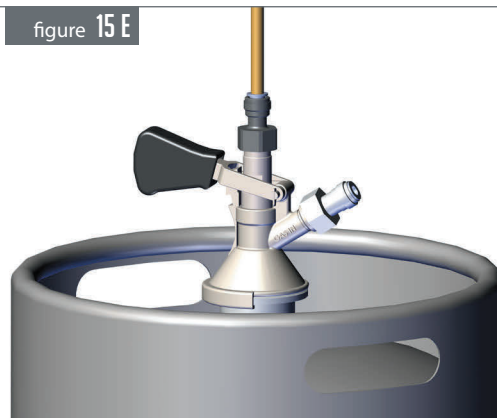

figure 16 A

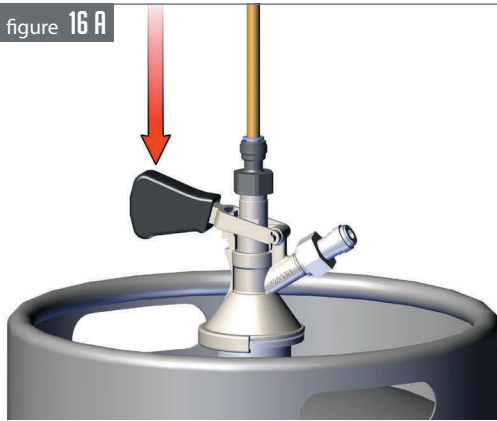
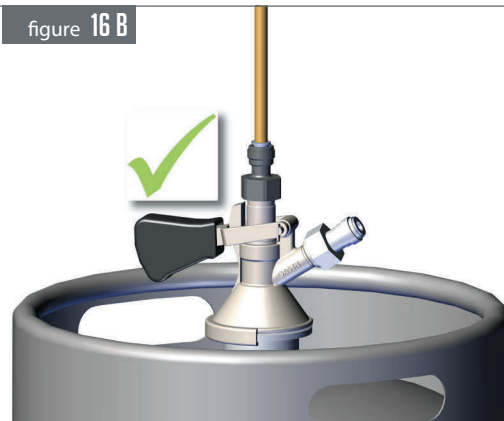

figure 16 B



16.4 Keg Untapping

Procedure for untapping a keg using an A-system keg coupler:

figure 16 C

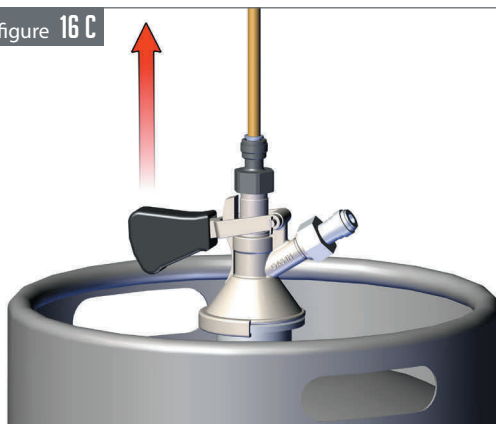
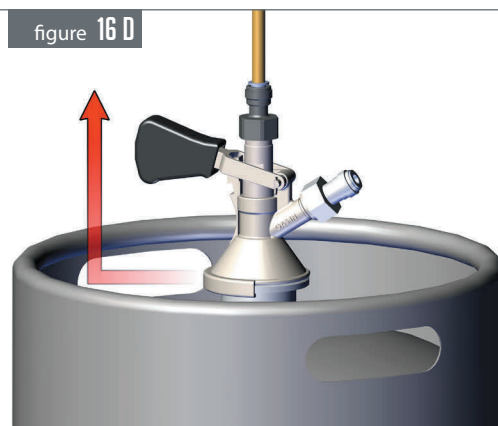

figure 16 D



16

17. PUTTING INTO OPERATION

1. Interconnect air supply and beverage supply.
2. Set the thermostat to 0 position.
3. Connect the cooler to the power mains.
4. Tap the keg in accordance with point 16.
5. Turn on the air compressor using the switch and pressurise to the required pressure.
6. Check that all the joints and connections are sufficiently tight.

⚠ WARNING: If a leakage is found, untap the keg according to point 16 and turn off the device. Fix any leaks found on the tubing. If a leak is found inside the device or you are unsure how to proceed, contact a service centre.

7. Use the dispensing tap to let out some of the beverage and check that there is no water in the device.

⚠ WARNING: Never set the device to maximum cooling if there is water in the device. May cause freezing of the beverage tubing and damage the device.

8. Set the desired temperature on the thermostat – see point 15.
9. The beverage is now cooling; once cooled (ca. 5-10 minutes) you can start pouring the first drink.

18. TABLE OF MALFUNCTIONS

<i>Malfunction</i>	<i>Cause</i>	<i>Removal</i>
beverage does not flow	keg tapped incorrectly	check that the keg coupler lever is pushed down
		device with built-in compressor - turn on the switch
	water from sanitation froze	turn off the device; then wait until the beverage starts flowing again (may take a few minutes, or hours!)
	compensator is closed	move the compensator lever on the tap
beverage cooled insufficiently	incorrect thermostat setting	turn the thermostat knob to the right towards number 7
	poor air circulation	check the cleanliness of condenser plates
	device overheats	place the device in a colder environment
tap jerks, drink sprays out	pressure too high	reduce delivery medium supply, reduce pressure in the keg
air compressor does not switch on		press the switch on the cooler
air compressor does not switch off	leakage	pull out and reinsert the air hose, tighten the nuts on the keg coupler
beer foams excessively		reduce beverage temperature - turn the thermostat knob to the right
		regulate flow rate by pushing the compensator lever up
speed fittings leaking	hose poorly inserted	pull out the hose, check that the end of the hose is flat (not at an angle), level off with a knife if needed
	scratches on the hose	pull out the hose and shorten by ca. 2 cm

i NOTE: If the defect persists even after the above steps are taken, contact a service centre.

Do not forget to specify the following:

- type of defect
- product type
- production year
- product's serial number (found on the machine plate)

Ordering Components

ALWAYS USE ORIGINAL COMPONENTS. The manufacturer or supplier bear no responsibility for non-original components or components not recommended by the manufacturer.

19. SPARE PARTS

When ordering spare parts, always provide the following:

- product type
- production year
- product's serial number
- full name of the spare part and its number

20. SANITATION BY WATER

(Sanitation Adapter)

Connect the sanitation adapter (not included) to water mains using a hose.

⚠ WARNING! Maximum water temperature must not exceed 25 °C.

figure 18 A

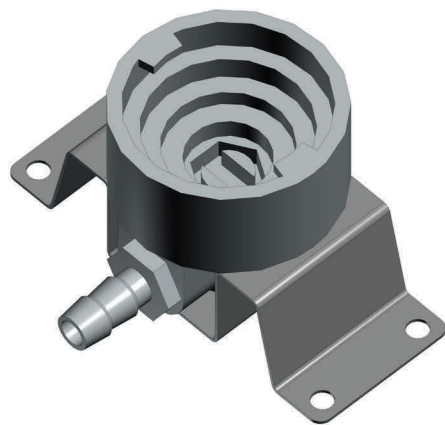
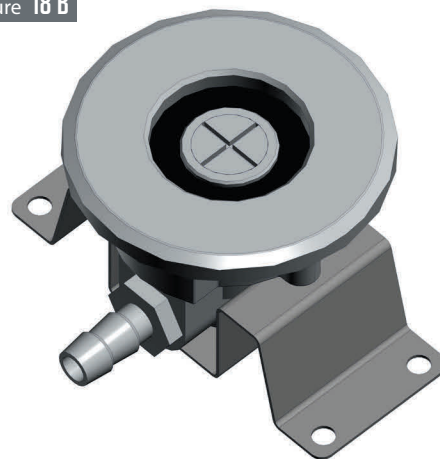

figure 18 B



i NOTE: Sanitation adapter is not included. Can be purchased as an accessory for the cooler.

Sanitation Procedure

Once you have finished a keg, connect the keg coupler to the sanitation adapter the same way as if you were tapping a keg. Once connected, turn the bar tap lever to open position and keep it open until clean water flows out of the tap (all beverage residue and partial sediments flush out). For better sanitation of the cooling device, place cleaning balls into the hose beyond the keg coupler and use pressurised water to clean out the beverage tubing.

i NOTE: Remember to dismount the tap and remove the cleaning balls.

21. MAINTENANCE

Flush the beverage tubing of the cooler after each use with pressurised water (see Sanitation by Water). To make flushing easier, use a sanitation adapter according to your type of keg coupler (not included in standard accessories). The cooler must be sanitised once every 14 days by a person with chemical

engineering qualifications. The condenser must be checked for cleanliness every month. Any dirt found must be cleaned with compressed air or wiped off. Otherwise, there is a risk of reduced cooling output or damaging of the cooler.

22. INSPECTION BEFORE EVERY USE

1. Visual check.
2. Lead-in cable check.
3. Condenser cleanliness check (in case of excess pollution of the condenser, clean more frequently than 1x a month).

 **WARNING:** Do not use the device if defects or malfunctions are found.

23. PERIODIC CHECKS

- ✓ 1x a week: check that the lead-in cable is undamaged and that the plug is firmly in the socket.
- ✓ 1x a week: check that the device is not exposed to radiant heat.
- ✓ 1x a week: check that air circulation is not obstructed.
- ✓ 1x a month: check the cooling unit's condenser and clean it regularly.
- ✓ 1x a year: have an engineering inspector check the electrical safety of the device.

24. ENVIRONMENTAL PROTECTION

Waste Sorting

 This product must not be disposed of in communal waste. Electrical waste in the Czech Republic is disposed of within the Rema System (www.remasystem.cz).

In countries other than the Czech Republic, waste sorting is subject to local regulations.

 Sorting waste allows recycling and reusing used products and packaging materials. Reuse of recycled material helps protect the environment from pollution and reduces resource consumption. Local regulations may regulate the method of disposing of household appliances at local collection points or at the point of sale.

PRODUCT MODEL	COOLING POWER OF THE COMPRESSOR (HP)	COOLING POWER OF THE COMPRESSOR (W)	MAXIMUM COOLING CAPACITY (L/HOUR) TO 0°C / TX 45°C	CONTINUOUS COOLING PERFORMANCE	THERMAL GRADIENT ΔT (°C)	TYPE OF REFRIGERANT	VOLTAGE	POWER (W)	AMPERAGE (A)	DIMENSION OF THE CABINET (SHXV MM)	NET WEIGHT (KG)
PYGMY 20 GREEN LINE	1/8	280	25	20	10	R290	220-240V 50Hz~1	253	1,10	170x280x325	13,5
PYGMY 20/K GREEN LINE	1/8	280	25	20	10	R290	220-240V 50Hz~1	322	1,40	170x280x325	15,5
PYGMY 25 GREEN LINE	1/8	310	35	25	10	R290	220-240V 50Hz~1	299	1,30	170x280x325	14,5
PYGMY 25/K GREEN LINE	1/8	310	35	25	10	R290	220-240V 50Hz~1	368	1,60	170x280x325	16,5
PYGMY 30/KPROFI	1/8	280	35	30	10	R134a	220-240V 50Hz~1	345	1,50	180x340x350	19,0
KONTAKT 40 GREEN LINE	1/5	510	50	40	10	R290	220-240V 50Hz~1	322	1,40	225x330x425	26,0
KONTAKT 40/K GREEN LINE	1/5	510	50	40	10	R290	220-240V 50Hz~1	391	1,70	225x330x425	29,0
KONTAKT 40/K PROFI GREEN LINE	1/5	510	50	40	10	R290	220-240V 50Hz~1	391	1,70	225x330x425	29,0
KONTAKT 70 GREEN LINE	1/3	860	90	70	10	R290	220-240V 50Hz~1	506	2,20	245x340x440	27,5
KONTAKT 70/K GREEN LINE	1/3	860	90	70	10	R290	220-240V 50Hz~1	598	2,60	245x340x440	29,5
KONTAKT 155/K GREEN LINE	3/4	1550	160	120	10	R290	220-240V 50Hz~1	966	4,20	265x380x495	42,0
KONTAKT 155 GREEN LINE	3/4	1550	160	120	10	R290	220-240V 50Hz~1	874	3,80	265x380x495	39,5
KONTAKT 155/R GREEN LINE	3/4	1550	160	120	10	R290	220-240V 50Hz~1	874	3,80	265x380x495	41,5
PYGMY 25	1/8	320	30	25	10	R134a	220V 60Hz~1	264	1,20	170x280x325	13,0
PYGMY 25/K	1/8	320	30	25	10	R134a	220V 60Hz~1	330	1,50	170x280x325	15,0
KONTAKT 40/K	1/5	630	50	40	10	R134a	220V 60Hz~1	462	2,10	225x330x425	29,0
KONTAKT 40	1/5	630	50	40	10	R134a	220V 60Hz~1	396	1,80	225x330x425	26,0
KONTAKT 70/K	3/8	1050	90	70	10	R134a	220V 60Hz~1	814	3,70	245x340x440	31,0
KONTAKT 115	1	1550	140	120	10	R134a	220-240V 50Hz~1	1288	5,60	265x380x495	45,5

