

Dolium® 24L S

PRODUCT NUMBER : 10-24S-01

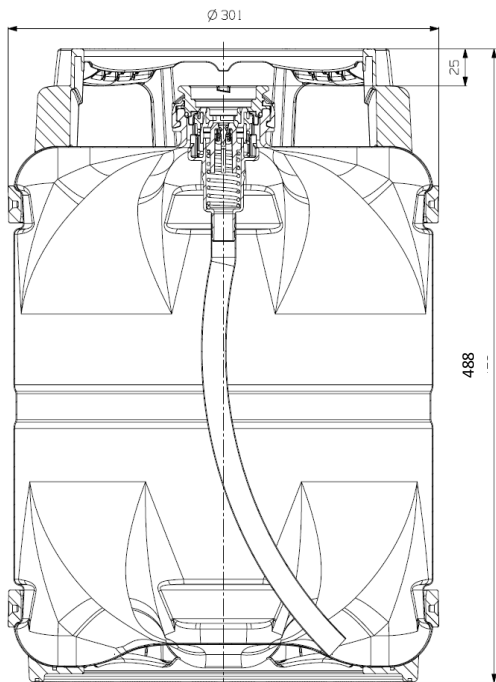
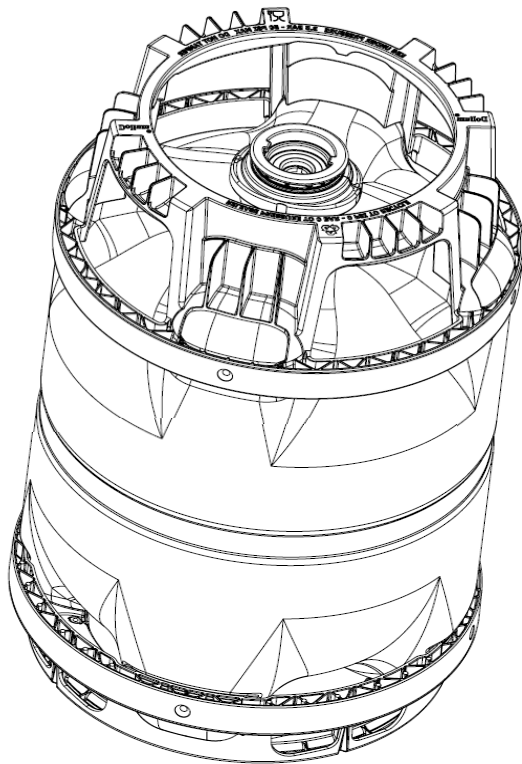

Characteristics

**KEG**

Cycle	single use
Volume	24L
Dimensions	D x H = 301 x 488 mm
Weight (empty)	1,20 kg
Temperature	0°C < T < 35°C
Pre- pressure	1,0 bar CO2
Working pressure	3,5 bar max.
Pressure Relief Valve	4,8 bar +/- 0,2 bar

**CONTAINER**

Oxygen ingress	Active barrier
Carbondioxide	Passive barrier
UV ingress	UV light barrier

**CONNECTION**

Type	Well type = S(ankey)-type
------	---------------------------

**CHIMES**

Handling	vertical and horizontal
Storage	stackable

**APPLICATIONS**

Products	Beverages
Shelf life	Equal to stainless steel
Certificates	EU / FDA
Filling line	compatible - check recommended
Draught installation	compatible
Recycable	100%

for further detailed information please see Handling & Safety instructions

Special features

Contact

Dispack-projects NV  
 Address: Vossesdijstraat 192A  
 Town: 2030, Antwerpen  
 Country: Belgium  
  
 E-mail: sales@dolium.eu  
 Website: www.dolium.eu